

SHF 軸心固定座

Flanged Shaft Supporter

材質：鋁合金 Material : Aluminum alloy

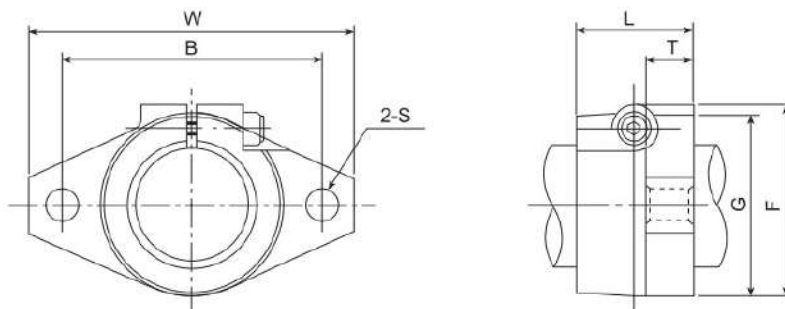

單位(unit) : mm

型號 Model No.	軸徑 Nominal shaft diameter	主要尺寸 Main dimensions							固定螺栓 Clamping bolt	裝配螺栓 Mounting bolt	重量 Weight g
		W	L	T	F	G	B	S			
SHF10	10	43	10	5	24	20	32	5.5	M5	M4	13
SHF12	12	47	13	7	28	25	36	5.5	M5	M4	20
SHF13	13	47	13	7	28	25	36	5.5	M5	M4	20
SHF16	16	50	16	8	31	28	40	5.5	M5	M4	27
SHF20	20	60	20	8	37	34	48	7	M6	M5	40
SHF25	25	70	25	10	42	40	56	7	M6	M5	60
SHF30	30	80	30	12	50	46	64	9	M8	M6	110
SHF35	35	92	35	14	58	50	72	12	M10	M8	380
SHF40	40	102	40	16	67	56	80	12	M10	M10	510
SHF50	50	122	50	19	83	70	96	14	M12	M12	890
SHF60	60	140	60	23	95	82	112	14	M12	M12	1,500