

# LGD12E 軸心式滑軌(不生銹)

Anticorrosive Linear Guide

經濟型 Economical Type

一個滑塊含4個滾輪軸承

One Block with 4 Rolling Bearings

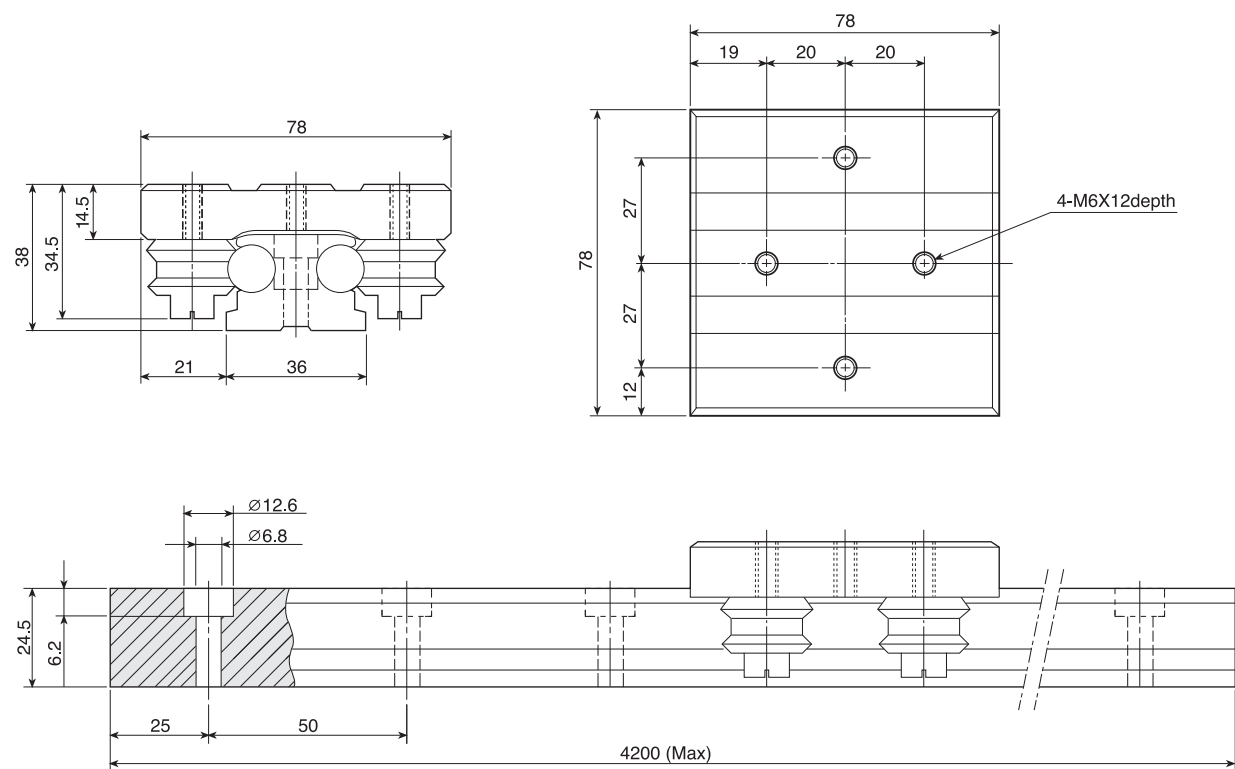

訂購例：

**LGD12E-B2-R1800C**

① ② ③

① 型號：LGD12E

② 1支滑軌上滑塊之個數：

B1: 1個、B2: 2個、B3: 3個, ...

③ 滑軌長度(1800mm):

軸心：熱處理(HRC 62±2), 鍍硬鉻及研磨

軸徑 Shaft diameter (mm)	基本動定格荷重 Basic dynamic load rating C (kgf)	基本靜定格荷重 Basic static load rating Co(kgf)	容許靜力矩 Allowable static moment			重量 Weight	
			To (kgf-m)	Tx (kgf-m)	Ty (kgf-m)	滑塊 Block kg	軌道 Track rail kg/m
12	140	230	4.3	3.2	3.8	0.36	3.2

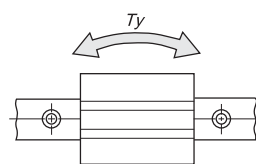
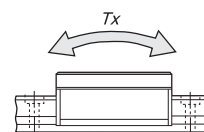
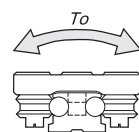

Example of identification number:

**LGD12E-B2-R1800C**

① ② ③

① Model No.:LGD12E

② Number of blocks per track rail:

B1: 1 Block B2: 2 Blocks B3: 3 Blocks, ...

③ Length of track rail (1800mm):

Shaft:Hardened(HRC 60±3)ground and chromium plated

# LGD12XL 軸心式滑軌(不生銹)

Anticorrosive Linear Guide

荷重型 Heavy Load Type

一個滑塊含8個滾輪軸承

One Block with 8 Rolling Bearings

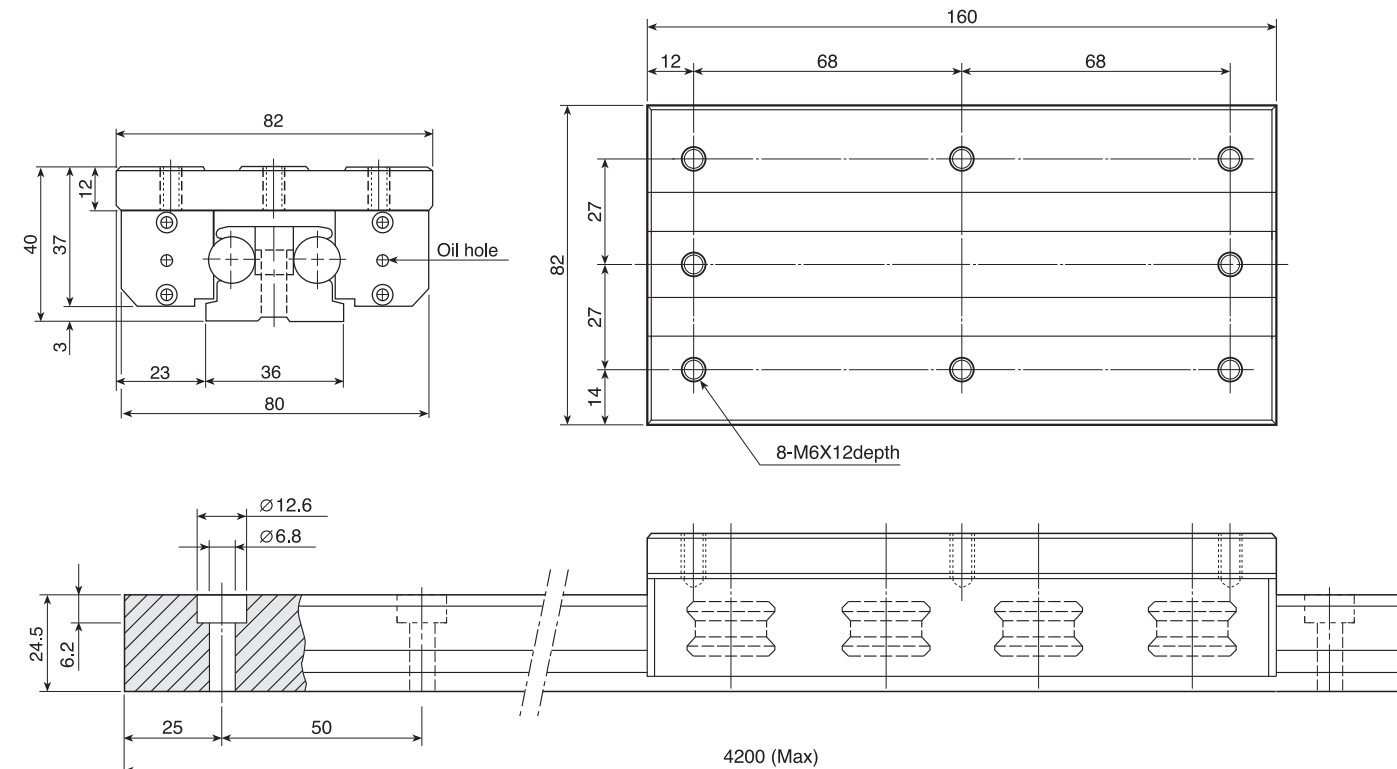

訂購例：

**LGD12XL-B2-R1800C**

① ② ③

① 型號：LGD12XL

② 1支滑軌上滑塊之個數：

B1: 1個、B2: 2個、B3: 3個, ...

③ 滑軌長度(1800mm):

軸心：熱處理(HRC 60±3), 鍍硬鉻及研磨

軸徑 Shaft diameter (mm)	基本動定格荷重 Basic dynamic load rating C (kgf)	基本靜定格荷重 Basic static load rating Co(kgf)	容許靜力矩 Allowable static moment			重量 Weight	
			To (kgf-m)	Tx (kgf-m)	Ty (kgf-m)	滑塊 Block kg	軌道 Track rail kg/m
12	290	460	8.7	11.2	13.6	0.86	3.2

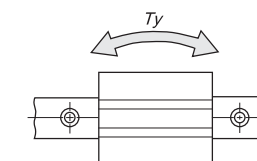
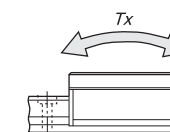
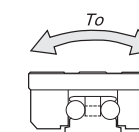

Example of identification number:

**LGD12XL-B2-R1800C**

① ② ③

① Model No.:LGD12XL

② Number of blocks per track rail:

B1: 1 Block B2: 2 Blocks B3: 3 Blocks, ...

③ Length of track rail (1800mm):

Shaft:Hardened(HRC 60±3)ground and chromium plated